

SPECIFICATIONS / JD800E-II

Overall Dimensions	
Gross Weight	14,800 kg / 32,950 lbs
Overall Length	10,100 mm / 33.2 ft
Overall Width	2,475 mm / 8.12 ft
Overall Height	3,390 mm / 11.12 ft
Crawler	
Ground Clearance	490 mm / 1.6 ft
Oscillating Angle	10/8°
Gradeability	30°
Traveling Speed	3.3 kmh / 2.1 mph
Engine <i>Cummins QSB6.7 TIER 4</i>	
Rated Output	173 bhp / 2,200 rpm
Dust Collector	
# of Filters	4

Drifter <i>YH-80A</i>	
Weight	210 kg / 463 lbs
Impact Frequency	40~45 Hz
Rotational Torque	Max. 59kgfm / 427flbs
Rotational Frequency	Max. 150 RPM
Impact Pressure	Max. 140bar / 2,031psi
Rotation Pressure	Max. 140bar / 2,031psi
Flushing Pressure	Max 10.5bar / 150psi
Bit & Rod	
Bit Diameter	Φ76 ~ Φ115 / 3"~4.5"
Rod Length	3,660 mm / 12 ft
Rod Section	T45/T51
Hydraulic System <i>Kawasaki</i>	
Hydraulic Pump	2 Variable Piston Pump + 1 Gear Pump 1 Gear Pump (Cooler)

Boom	
Overall Length	2,840 mm / 9.32 ft
Lift Angle	50 U° / 15 D°
Swing Angle	35 R° / 25 L°
Auto Rod Changer <i>Carousel Type</i>	
# of Rod Installed	4+1 EA
Air End	
Working Pressure	10.5 kg-cm2 / 150 psi
Free Air Delivery	6.6m3 / 233 cfm
Guide	
Overall Length	7,590 mm / 24.9 ft
Slide Length	1,500 mm / 4.92 ft
Feed Length	4,300 mm / 14.1 ft
Swing Angle	65 R° / 50 L°
Tilt Angle	180°

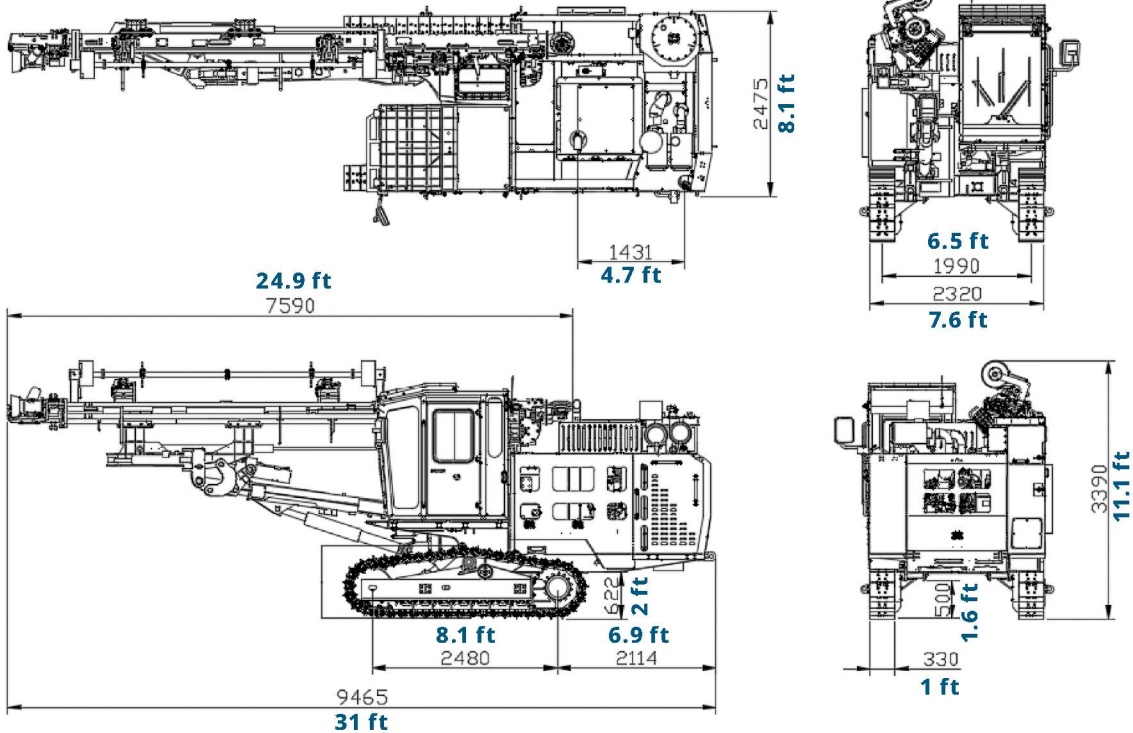

(502) 244-0004
john@rockdrills.net



SoosanAmerica.com
RockDrills.net